

11 Series Heavy Duty Electric Strikes

IPIXA Security 11 Series electrified & Fire sereis is developed to support the need for security applications for doors used for fire escape routes & for those doors which would require electrified door locks & associated accessories

11 Series Electric Strike is a compact, high performance heavy duty electric strike designed for low profile openings. The strength is derived from a unique and patented keeper pin locking design, enabling the strike to exceed the rating of the frame, door and locking hardware.



AFS1122

Product Specifications

- Suitable for Metal & Wood Frame
- Dual voltage 12//24 VDC
- 320 mA at 12 VDC/160 mA at 24 VDC
- PoE friendly
- Tamper Resistant
- Static Strength 2200lbs
- Endurance 1 Million Cycles
- Field Selectable Fail Safe / Fail Secure
- In-Built Latchbolt Monitor
- ANSI BHMA Standard

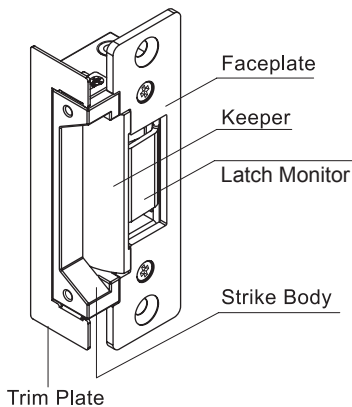
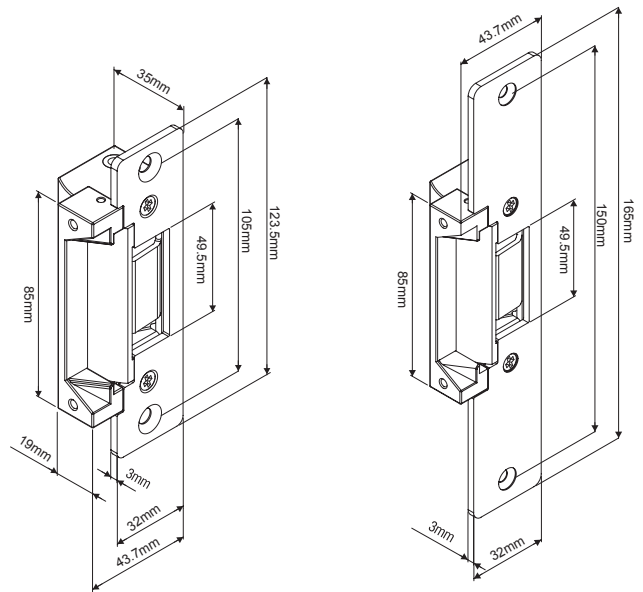

**Endurance Tested
1,000,000
Cycles**



IPIXA SECURITY LIMITED
Kemp House, 160 City Road,
London, EC1V 2NX,
United Kingdom
ipixa.co.uk