

02 Series Electromagnetic Locking Range

IPIXA Security 02 Series Electromagnetic Locking Range represents reliable and cost effective Access Control solution

IPIXA offers various types of Brackets which can be used depending on the installation scenario.



AEL0204

Product Specifications

Material	: Aluminium
Type	: Z Bracket
Cycle Testing	: 500,000 Cycles
Door Type	: Wood, Metal
Weight	: 0.16kg
Dimensions	: 70 (L) x 38 (W) x 38 (H) mm
Application	: Z Bracket suitable for cabinet/security racks. To be used with Mini Maglock Model: AEL0201



Cycle Tested
500,000

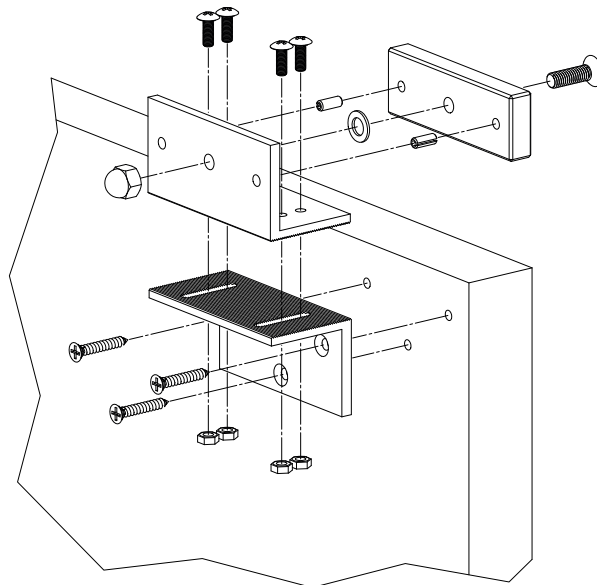
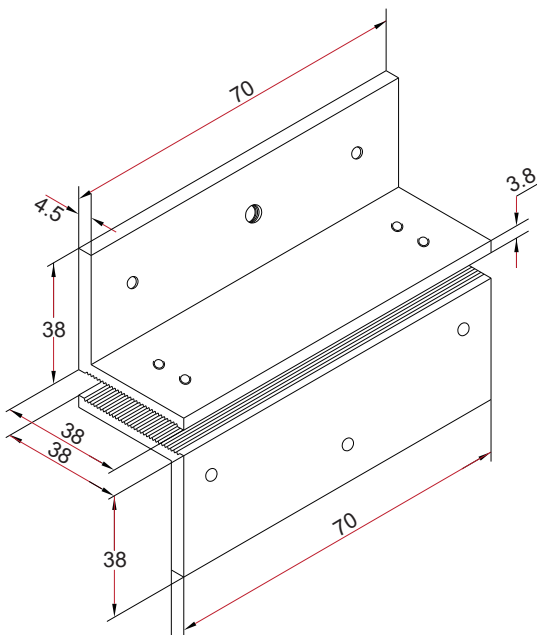

★ ★ ★
3
YEARS
WARRANTY

IPIXA SECURITY LIMITED
Kemp House, 160 City Road,
London, EC1V 2NX,
United Kingdom
ipixa.co.uk